

DOS-001



single piston oil pressure standard



Table of Contents

1	introduction.....	1
1.1	general product description.....	1
1.2	operating principle.....	1
2	general specifications.....	4
2.1	piston cylinders.....	4
2.2	mass set.....	5
2.2.1	available mass set configurations.....	5
2.3	instrument outline.....	6
2.3.1	front view.....	6
2.3.2	top view.....	6
3	installation.....	7
3.1	as received.....	7
3.2	site requirements.....	7
3.3	filling up.....	8
4	operating DOS-001.....	9
4.1	setting a line pressure.....	9
5	maintenance.....	10
5.1	changing lubricating fluid / cleaning piston cylinder.....	10
5.2	overhaul.....	11
5.3	recalibration.....	11
6	parts list.....	12

1 introduction

1.1 general product description

The Stiko DOS-001 Pressure Standard is an oil operated deadweight tester used for calibrating test gauges, transducers and transmitters at pressures up to 200 MPa. The system consists of the following main components :

deadweight tester platform	x
piston cylinder assembly	x
mass set	1 set
pressure control	manual operated variable volume

1.2 operating principle

The primary function of the system is to combine two primary metro logical quantities:

1. the piston-cylinder which defines an effective area, A .
2. the masses, value m , which press on the piston with a force F .

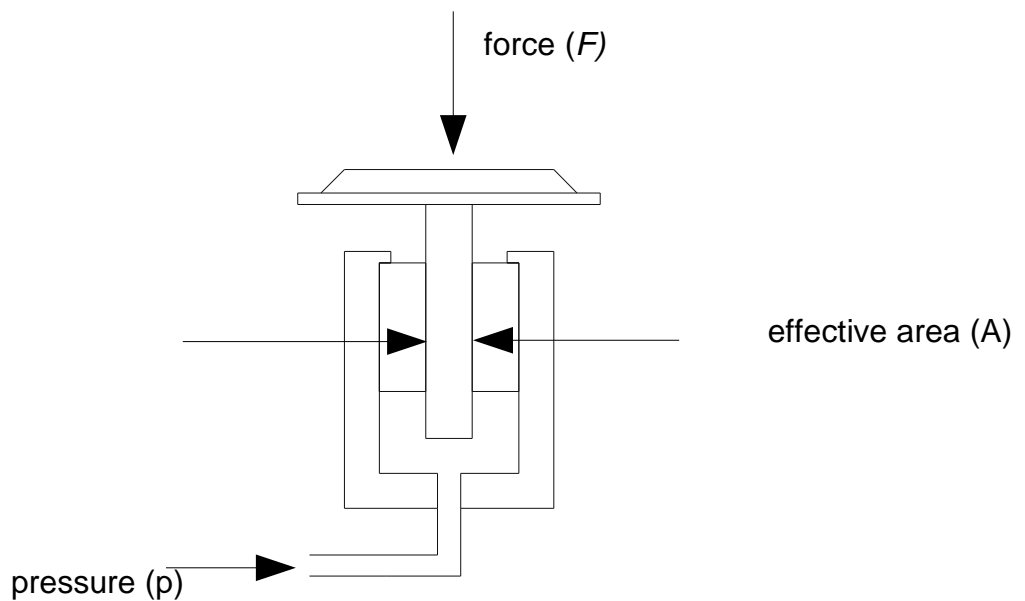

The value of the pressure p_e which puts the piston into equilibrium is given by the formula:

$$p_e = \frac{m_c \cdot (1 - \rho_a / \rho_m) \cdot g_l + \pi \cdot d \cdot \tau}{A_{20} \cdot (1 + (\alpha_p + \alpha_c) \cdot (t - 20))} \cdot 10^{-3} \quad [\text{kPa}]$$

where	p_e	: gauge pressure at reference level	[kPa]
	m_c	: conventional mass	[kg]
	$1 - \rho_a / \rho_m$: air buoyance correction	(= 0,99985) [-]
	g_l	: local gravity	[N/kg]
	$\pi \cdot d$: piston circumference	[m]
	τ	: surface tension oil	(=0,031) [N/m]
	A_{20}	: effective area at 20 °C / mid pressure	[m ²]
	$\alpha_p + \alpha_c$: thermal expansion coefficient piston + cylinder	[°C ⁻¹]
	t	: piston cylinder temperature	[°C]

The oil lubricated / oil operated pistons of the DOS series are specially designed to have superior performance and a high rangeability. Standard mass load range is 1 .. 100 kg and can be expanded downwards to 200 g with an optional mass adaptor.

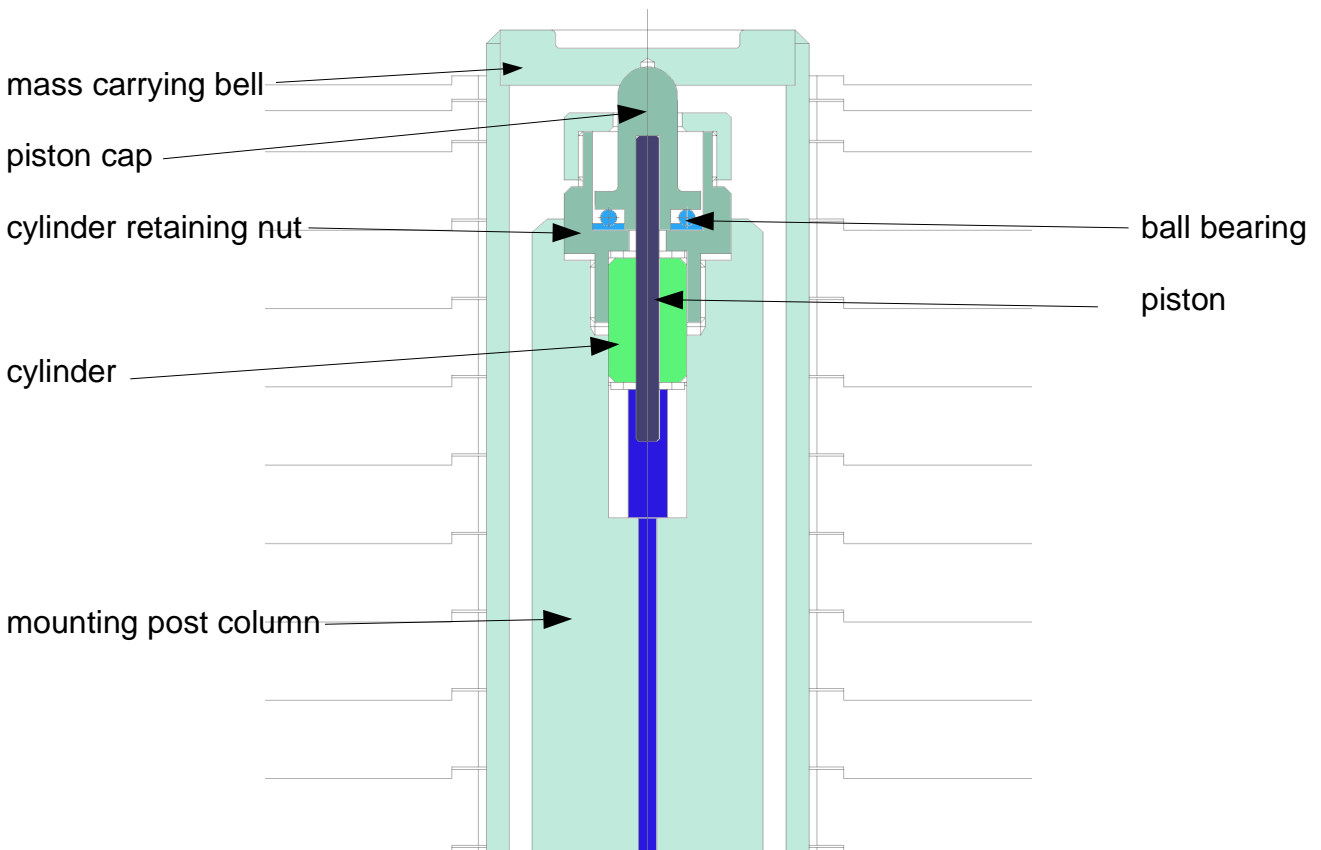

2 general specifications

pressure range	0,5 .. 50 / 2 .. 200	MPa g
measurement uncertainty p	$1 \cdot 10^{-4} \cdot p_e + 100$ Pa	
certification	standard delivered with EA ¹ certificate	
pressure connections	3/8" BSP LH with BSP adapters	
platform	stainless steel triangle shape	
footprint base plate	520 x 320	mm
overall height	315	mm
pressure media oil	DWT oil 812	

2.1 piston cylinders

material cylinder	tungsten carbide		
material piston	tungsten carbide	special steel	
nominal piston diameter	5	2,5	mm
nominal K_n	500 kPa/kg	2 MPa/kg	
thermal expansion	$9 \cdot 10^{-6}$	$11 \cdot 10^{-6}$	°C ⁻¹
type	re-entrant		
medium	oil operated / oil lubricated		
certification	EA calibrated on effective area		

1 European Accreditation, see <http://www.european-accreditation.org>

2.2 mass set

description	nominal mass	
mass carrier (piston mass included)	1	kg
	4	kg
	2	kg
	1	kg
	500	g
	200	g
	100	g
optional	1 x 50	g
	2 x 20	g
	1 x 10	g
	1 x 5	g
	2 x 2	g
	1 x 1	g
certification	EA certification on conventional mass	

2.2.1 available mass set configurations

mass set kg	carrier kg	4 kg	2 kg	1 kg	0.5 kg	0.2 kg	0.1 kg	lo p range	hi p range
								bar	bar
5	1	0	1	1	1	2	1	5 - 25	20 - 100
10	1	1	1	2	1	2	1	5 - 50	20 - 200
15	1	2	2	1	1	2	1	5 - 75	20 - 300
25	1	5	1	1	1	2	1	5 - 125	20 - 500
35	1	7	2	1	1	2	1	5 - 175	20 - 700
45	1	10	1	1	1	2	1	5 - 225	20 - 900
55	1	12	2	1	1	2	1	5 - 275	20 - 1100
65	1	15	1	1	1	2	1	5 - 325	20 - 1300
75	1	17	2	1	1	2	1	5 - 375	20 - 1500
85	1	20	1	1	1	2	1	5 - 425	20 - 1700
101	1	24	1	1	1	2	1	5 - 505	20 - 2020

2.3 instrument outline

2.3.1 front view

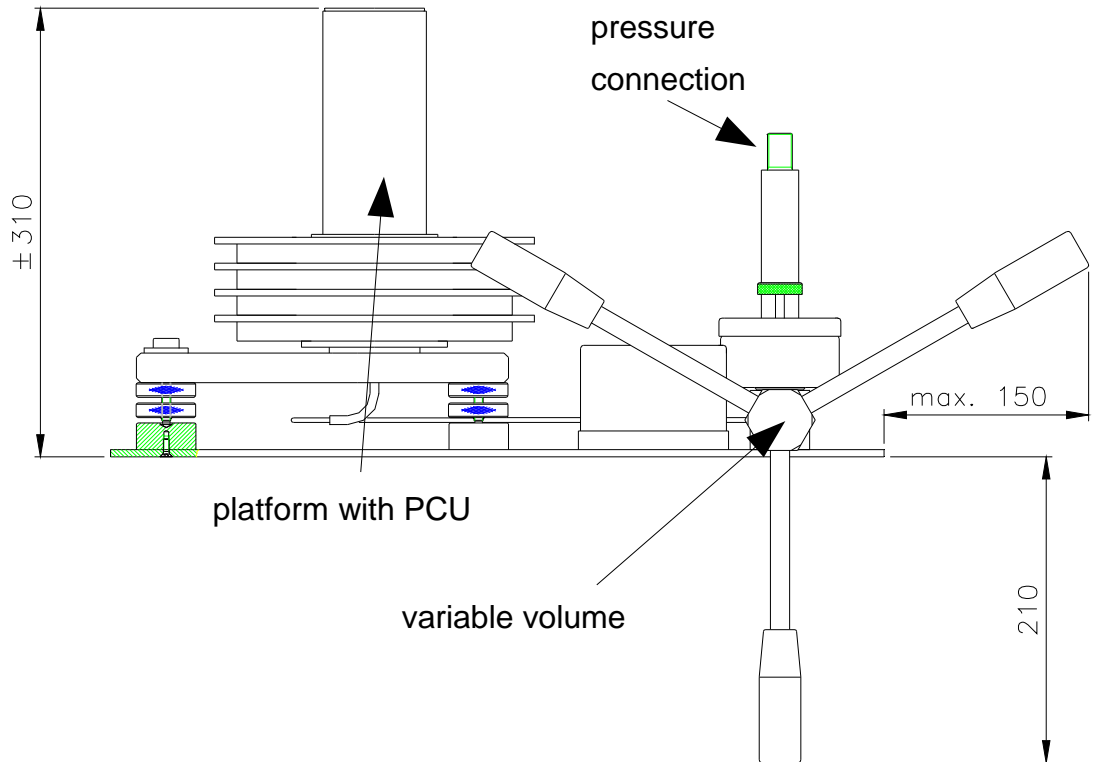

2.3.2 top view

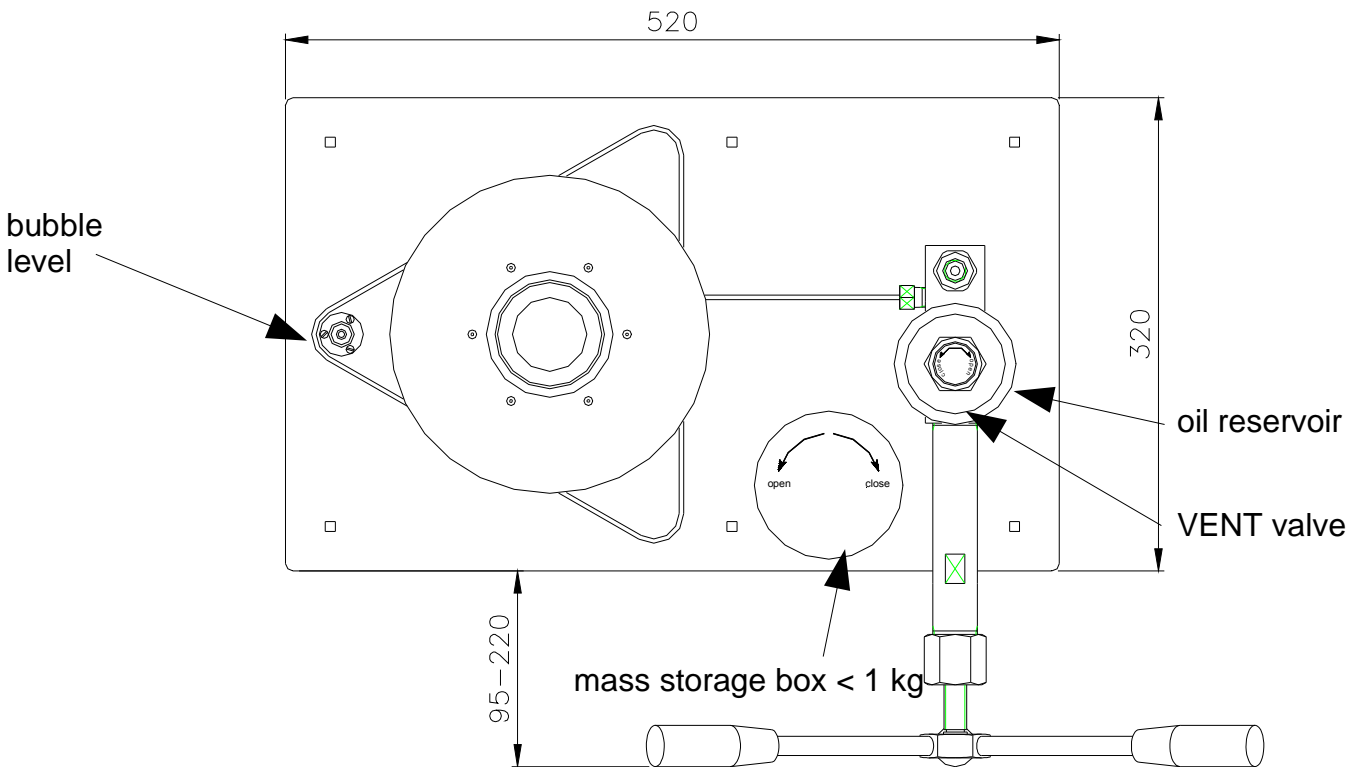

3 installation

3.1 as received

The DOS-001 is sealed in plastic and packed in an export quality wooden crate. When opening the box, check the contents against the scope of delivery.

! As the piston cylinder mounting system is specially designed to protect the piston, they are normally mounted into the mounting post with a plastic transport cap. This protection is sufficient for transport and long term storage.

! The DOS-001 is transported with minimal lubricating oil, do not operate the instrument before purging the system.

3.2 site requirements

The DOS-001 is delivered with a mounting plate which is designed to contain the platform and variable volume pump. Tailor made interconnection hardware is also included in the scope of delivery.

- The room in which the instrument is placed should have proper founding, no vibrations are allowed during operation of the DOS-001 as this results in unpredictable errors.
- The DOS-001 should be placed on a rugged table which is rated for at least 140 kg without deforming. The table should be horizontally leveled.
- The DOS-001 mounting plate can be fixated on the table with stainless steel locking bolts (in the scope of delivery).
- Air movement in the neighborhood of the DOS-001 should be avoided.
- Room temperature needs to be stable during the time the DOS-001 is used to avoid uncertainties due to the thermal expansion coefficients of the piston cylinder and adiabatic effects in the measuring system.

3.3 filling up

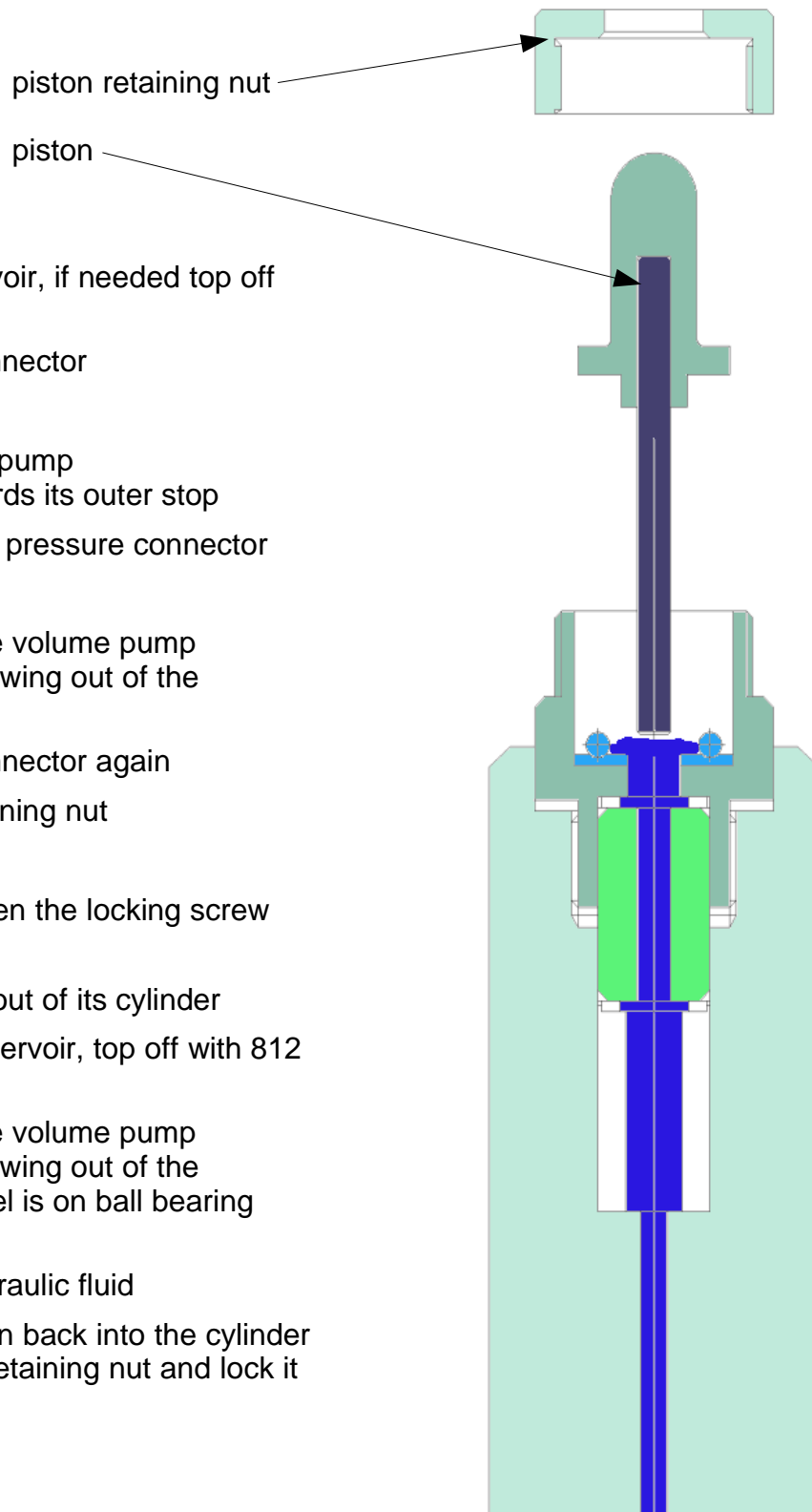

- check oil level in reservoir, if needed top off with 812 hydraulic oil
- plug DUT pressure connector
- open VENT valve
- rotate variable volume pump counterclockwise towards its outer stop
- remove plug from DUT pressure connector
- close VENT valve
- carefully rotate variable volume pump clockwise until oil is flowing out of the pressure connector
- plug DUT pressure connector again
- remove the piston retaining nut

! do not forget to loosen the locking screw

- carefully lift the piston out of its cylinder
- check oil level in oil reservoir, top off with 812 hydraulic oil if needed
- carefully rotate variable volume pump clockwise until oil is flowing out of the cylinder and the oil level is on ball bearing level
- wet the piston with hydraulic fluid
- carefully slide the piston back into the cylinder and mount the piston retaining nut and lock it again
- DONE

! Make sure that after purging the oil level in the reservoir is sufficient for normal operation

4 operating DOS-001

4.1 setting a line pressure

The DOS-001 piston diameter is designed to have a nominal mass to pressure factor of 5 or 20 bar/kg, e.g. 1 kg represents approximately 5 or 20 bar. To calculate the mass needed to approach a desired pressure, just divide the pressure by 5 or 20 to get the nominal mass load. When using a DOS-001 in normal conditions a mass loading resolution of 100 gram is good enough as you compare the calculated deadweight tester pressure with the actual readout of the DUT.

example :

nominal pressure point	94 bar g
nominal mass to pressure constant	5 bar/kg
calculated nominal mass	18,8 kg
$\pi \cdot d \cdot \tau$	0,00049 N
pressure calculation from certificate data	
local gravity	9,812703 N/kg
summarized conventional mass	18,8001 kg
effective area	0,196255 .10 ⁻⁴ m ²
calculated pressure	93,9862 bar g

So in the above example, we loaded :

piston+mass carrier	: 1 kg
4 kg nr. 1..4	: 16 kg
1 kg	: 1 kg
500 gr	: 0,5 kg
200 gr	: 0,2 kg
100 gr	: 0,1 kg

- open VENT valve
- rotate variable volume pump counterclockwise until 3/4 of its stroke
- close vent valve
- carefully rotate variable volume pump clockwise until piston starts floating
- carefully rotate piston clockwise (using three fingers on the mass carrying bell)
- fine tune the line pressure with the variable volume pump until the piston is in its mid stroke position

! piston mid stroke position is reached when the bottom of the mass carrying bell is levelled with the green colored band on the mounting post

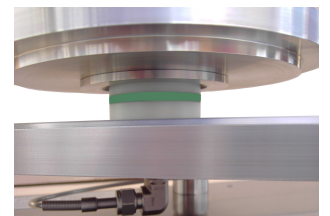

- ! the readout of the DUT can be used to monitor change in line pressure

5 maintenance

5.1 changing lubricating fluid / cleaning piston cylinder

It is good practice to change hydraulic fluid at least once every year.

- plug the DUT pressure connection
- make sure the deadweight tester is vented
- turn the variable volume clockwise till its inner stop
- remove the piston retaining nut, do not forget to loosen the locking screw

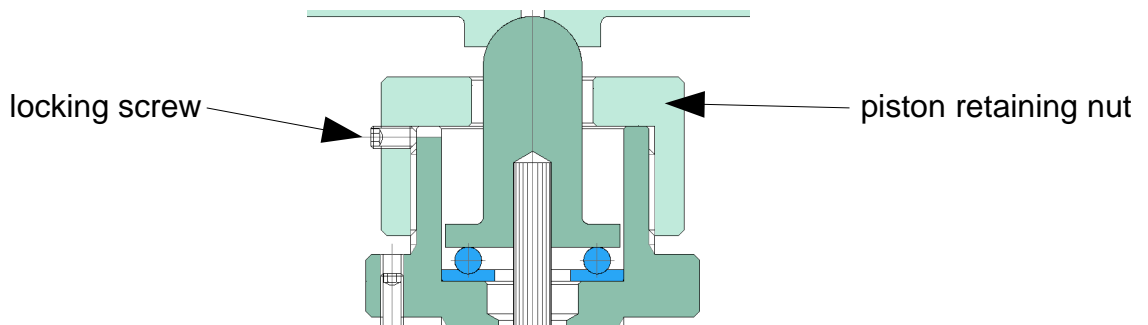

- place a towel around the base of the mounting post
- carefully lift up the piston out of the cylinder

When the piston is removed, the oil will flow to the oil reservoir.

- make sure the pressure connection is open to atmosphere, the oil in tubing towards the pressure connection will flow back to the oil reservoir
- remove the oil from the oil reservoir (for example with a syringe) and clean the reservoir with lint free cloth
- if necessary clean all surfaces with alcohol or cleaning solvent like Loctite 7063, also pour some solvent into the cylinder bore
- if necessary make use of compressed air to drive the solvent and residual oil from the cylinder towards the oil reservoir

- ! cover both the pressure connection and the reservoir with a towel to avoid unattended spraying of oil mist

- clean the piston with lint free cloth wetted with alcohol or cleaning solvent like Loctite 7061
- purge the system as described in section 3.3

- ! before assembly, make sure all solvent has vapoured

- ! the piston should be wetted with lubricating fluid before assembly

5.2 overhaul

The DOS-001 is designed to be almost maintenance free. The in 5.1 described cleaning is expected to be the only regular maintenance performed by the end-user. On the longer term it might be necessary to exchange the cylinder o-rings, for this a separate overhaul kit is available, including :

- overhaul manual
- cylinder removing tool
- bullet proof storage container for piston & cylinder
- spare o-ring kit

5.3 recalibration

Although the DOS-001 is designed to have a very good long term stability, a first recalibration at 2 years after purchase is recommended both for piston cylinder and mass set. The results of the recalibration can be used as a guideline for future recalibration. Depending on the environment and frequency of use a recalibration interval of 2 to 5 years is normal.

- ! It is not necessary to send the whole deadweight tester for recalibration, when the overhaul kit is purchased, the cylinder can be removed from the platform and shipped in the storage container.

6 parts list

product	part	code	qty.	remark
dead weight tester DOS-001	Mounting plate	520 x 320 mm	1	
	Weight column		1	oil driven
	O-ring	Ø17.12 x 2.62 90° NBR	1	for cilinder assembly
weight set	see section 2.2 for available mass sets			
pressure supply	Hand pump	oil operated	1	including valve and oil tank
	Tubing < 700 bar	Ø1/8" SS	-	
	Tubing > 700 bar	Ø 6 mm SS	-	
	O-ring	Ø5,23 x 2,62 90° shore	1	In oil valve
	O-ring	Ø23.5 x 2.4 70° shore	1	For oil reservoir
	O-ring	Ø18.6 x 2.4 70° shore NBR	1	for test connection
	U-cup	T20 8-16-5.7 1 (Merkel)	1	In oil pump piston
other	EAcertificate (RVA)		1	Minerva Meettechniek B.V.
	Weight box	for weight set	X	Depending on range
	Dust cover	for weight culomn	1	
	Protection tube	for piston in weight culomn	1	for transport
	Test connection	3/8"bsp LH with adapters	1	
	Adapter	1/8" BSP female	1	
	Adapter	1/4" BSP female	1	
	Adapter	3/8" BSP female	1	
	Adapter	1/2" BSP female	1	
	Multi seal	Ø13,2 x Ø6,9 x 1,2 mm	1	for test connection
	Bolt and nut	M6 x 50 A2	7	fixing mounting plate
	Dead weight tester oil	812	0.5 ltr	



Stiko Meetapparatenfabriek B.V.
Industrieweg 5, 9301 LM RODEN
P.O. Box 46, 9300 AA RODEN
The Netherlands
Tel. : +31 - (0)505013813
Fax.: +31 - (0)505013824
E-Mail: sales@stiko.nl
www.stiko.nl